

**G90-7**

TYPE 1

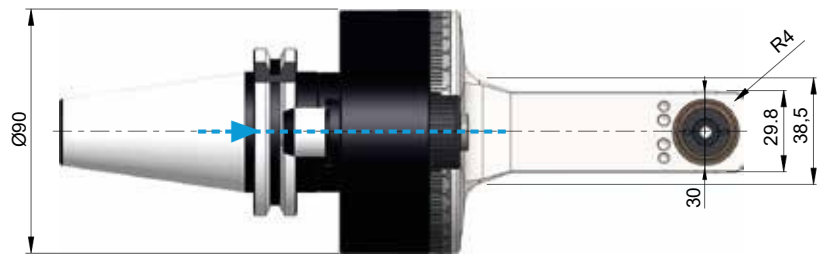

Technical data

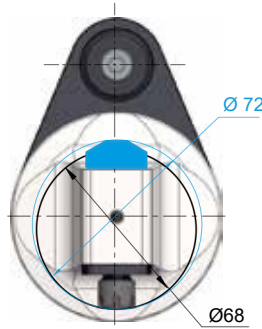
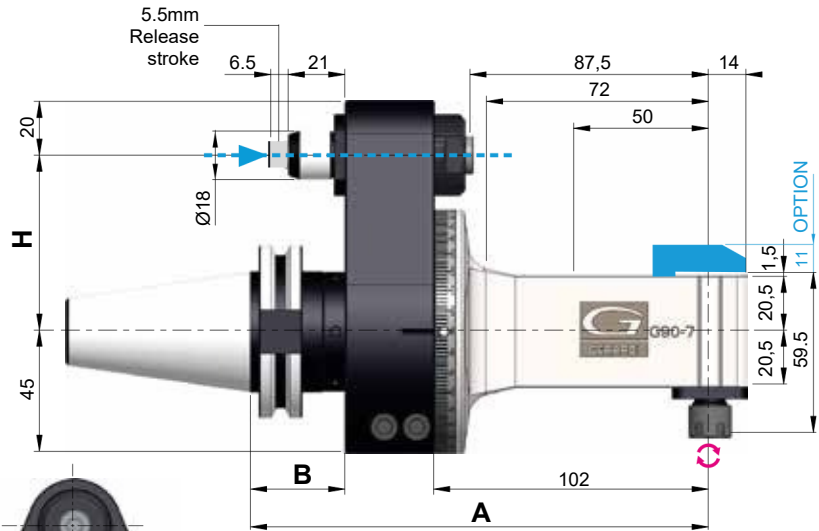

Ratio  
1:1



Kg 4



Rpm  
10.000



Ø 7



N 120



M 6



Nm 5



ER11  
Ø17



Direction of rotation Opposite to the machine spindle

Coni - Shanks	SK DIN 69871			CAT ANSI B5.50		BT MAS 403			HSK DIN 69893			C. ISO 26623			
Size	30	40	50	40	50	30	40	50	63	80	100	C5	C6	C8	
Dual contact (Optional)															
H	Standard	65 / 80	65 / 80	80	65 / 80	80	65 / 80	65 / 80	80	65 / 80	65 / 80	80	65 / 80	65 / 80	80
	Optional 110														
A	170	170	170	170	170	170	170	176	177	177	180	173	173	175	
B	35	35	35	35	35	35	35	41	42	42	45	38	38	40	

PACK WEIGHT:  
Bag 7Kg



STANDARD EQUIPMENT

Special bag / Stop block / ER nut / Wrenches  
/ Grease tube / Instruction book

OPTIONS

COOLANT - Pin through Max 10bar - 6000Rpm - **Dry running YES**

OUTPUT -Weldon Max Ø8

DOUBLE OUTPUT- ER11 - ER 8M