

GL90-10 TYPE 0

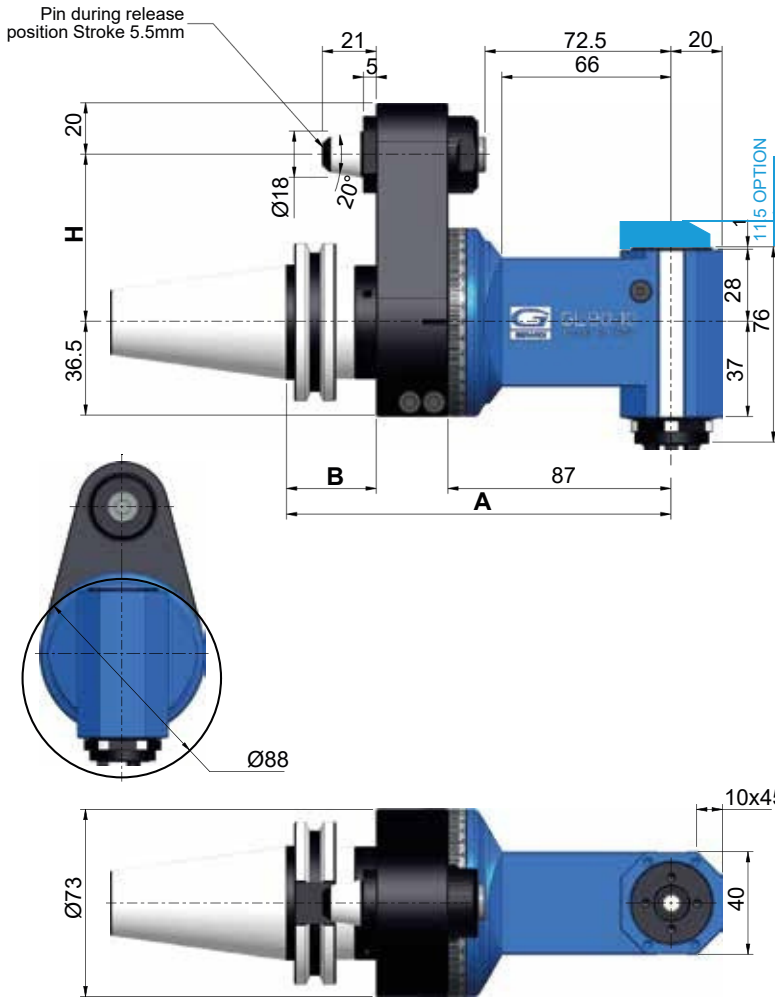

Technical data

	Ratio 1:1		ISO / BT 40 Kg 2,4 ISO / BT 50 Kg 2,9
	Rpm 10.000		Ø 10
	N 250		M 8
	Nm 10		ER16 Ø1/10

Direction of rotation Opposite to the machine spindle

Coni - Shanks	SK DIN 69871	CAT ANSI B5.50	BT MAS 403	HSK DIN 69893
Size	30 40	40	30 40	63
Dual contact (Optional)				
H	Standard 65 / 80 Optional 110	65 / 80	65 / 80	50 / 65 / 80
A	150	150	145	150
B	35	35	30	35
				157 42

PACK WEIGHT:
Bag 6Kg



STANDARD EQUIPMENT

Special bag / Stop block / ER nut / Wrenches / Grease tube / Instruction book

OPTIONS

COOLANT Pin through Max 10bar - 6000Rpm - **Dry running YES**

OUTPUT Weldon Max Ø12

OUTPUT - Shellmillholder Ø13

OUTPUT - ER20

DOUBLE OUTPUT -ER11 - ER 8M