

1

GL90-7

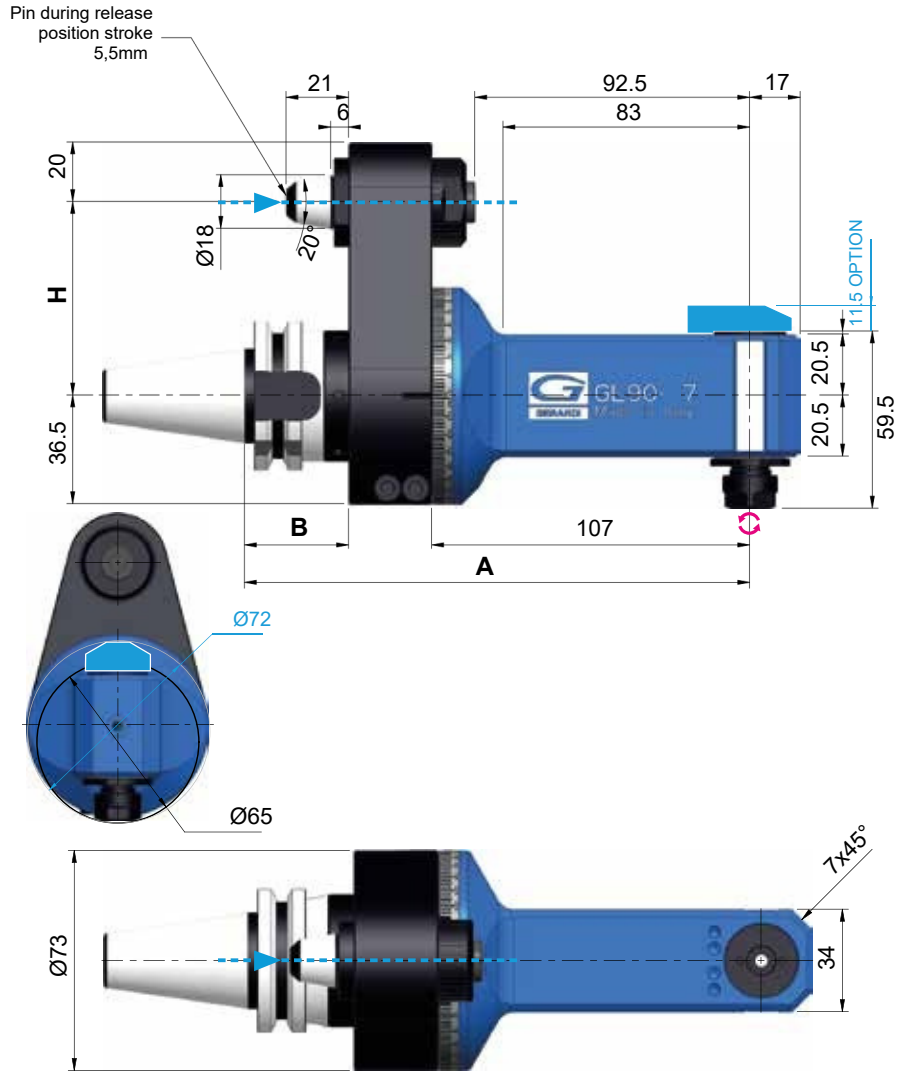

Technical data



Ratio
1:1



ISO / BT 30
Kg 2,2
ISO / BT 40
Kg 2,7



Rpm
10.000



Ø 7



N 120



M 6



Nm 5



ER11
Ø1/7



Direction of rotation Opposite to the machine spindle

Coni - Shanks	SK DIN 69871	CAT ANSI B5.50	BT MAS 403	HSK DIN 69893
Size	30 40	40	30 40	63
Dual contact (Optional)				
H Standard	65 / 80	65 / 80	65 / 80	65 / 80
Optional 110				50 / 65 / 80
A	170	170	170	170
B	35	35	35	30 35
				42

PACK WEIGHT:
Valigetta - Bag 5,5Kg



STANDARD EQUIPMENT

Special bag / Stop block / ER nut / Wrenches / Grease tube / Instruction book

OPTIONS

COOLANT Pin through Max 10bar - 6000Rpm **Dry running YES**

OUTPUT -Weldon Max Ø6

DOUBLE OUTPUT- ER11 - ER 8M