

GM90-3 TYPE 1
100

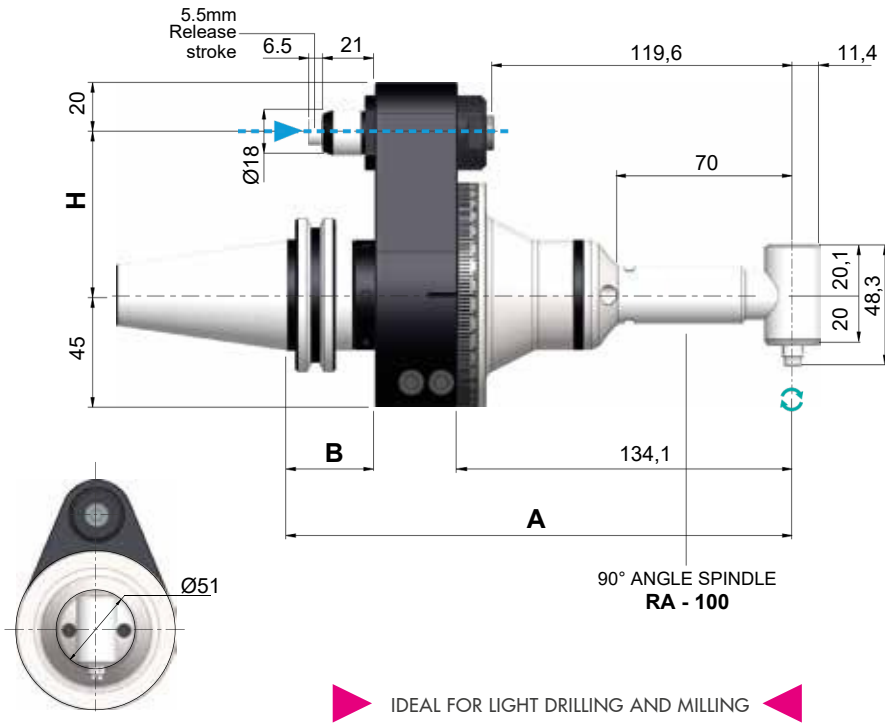

Technical data

	Reduction Ratio 1 / 2,67		Kg 3,8
	Rpm 15.000 / 5.620		Max Ø3,175
	-		-
	Nm 4		CH8: Ø 0,8-3,175

Direction of rotation Same as the machine spindle

Coni - Shanks	SK DIN 69871			CAT ANSI B5.50			BT MAS 403			HSK DIN 69893			C. ISO 26623		
Grandezza - Size	30	40	50	40	50	30	40	50	63	80	100	C5	C6	C8	
Dual contact (Optional)															
H Standard	65 / 80	65 / 80	80	65 / 80	80	65 / 80	65 / 80	80	65 / 80	65 / 80	80	65 / 80	65 / 80	80	
Optional 110															
A	202	202	202	202	202	202	202	208	209	209	212	205	205	207	
B	35	35	35	35	35	35	35	41	42	42	45	38	38	40	

PACK WEIGHT:
Bag 7Kg



STANDARD EQUIPMENT
Specialbag / Stop block / ER nut / Wrenches / Greasetube
Instruction book / CH8Ø3mm collet

OPTIONS

- 90° ANGLE SPINDLE - RA-200
- 90° ANGLE SPINDLE - MFC-300 S
- 90° ANGLE SPINDLE - IC-300
- EXTENSION - CN-01 H=50,1 mm