

GM90-3 TYPE 1
200



NEW
2025

Body

RA - 200

Technical data



Reduction Ratio
1:1,5



Kg Kg 3,7



Rpm
15.000 /
10.000



Ø 3,175
Max



Nm 4



CHS: Ø
0,8-3,175

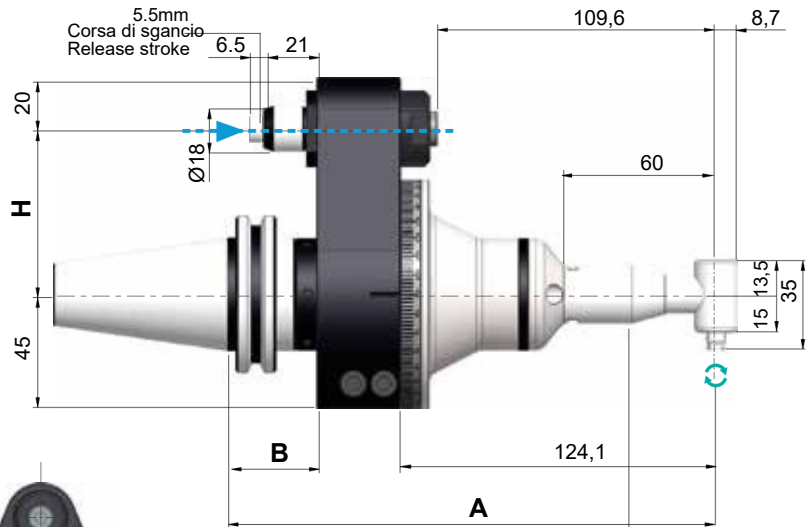

90° ANGLE SPINDLE
RA - 200



▶ IDEAL FOR LIGHT DRILLING AND MILLING ◀

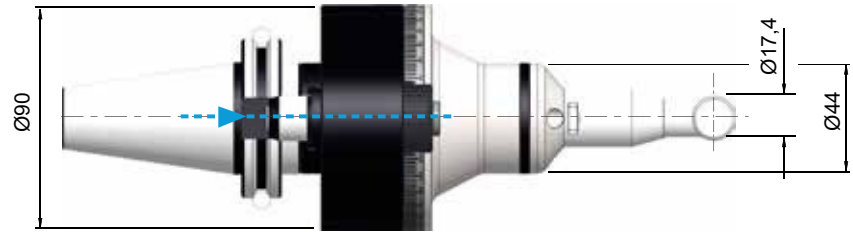

Direction of rotation Same as the machine spindle

Coni - Shanks	SK DIN 69871			CAT ANSI B5.50		BT MAS 403			HSK DIN 69893			C. ISO 26623		
Size	30	40	50	40	50	30	40	50	63	80	100	C5	C6	C8
Dual contact (Optional)														
H Standard	65 / 80	65 / 80	80	65 / 80	80	65 / 80	65 / 80	80	65 / 80	65 / 80	80	65 / 80	65 / 80	80
Optional 110														
A	192	192	192	192	192	192	192	198	199	199	202	195	195	197
B	35	35	35	35	35	35	35	41	42	42	45	38	38	40

PACK WEIGHT: Bag 7Kg



STANDARD EQUIPMENT

Specialbag / Stop block / ERnut / Wrenches / Greasetube
Instruction book / K252 Ø1,6mm collet

OPTIONS

90° ANGLE SPINDLE - RA-100

90° ANGLE SPINDLE - MFC-300 S

90° ANGLE SPINDLE - IC-300

EXTENSION - CN-01 H=50,1 mm