

**GM90-3** TYPE 1  
**300S**

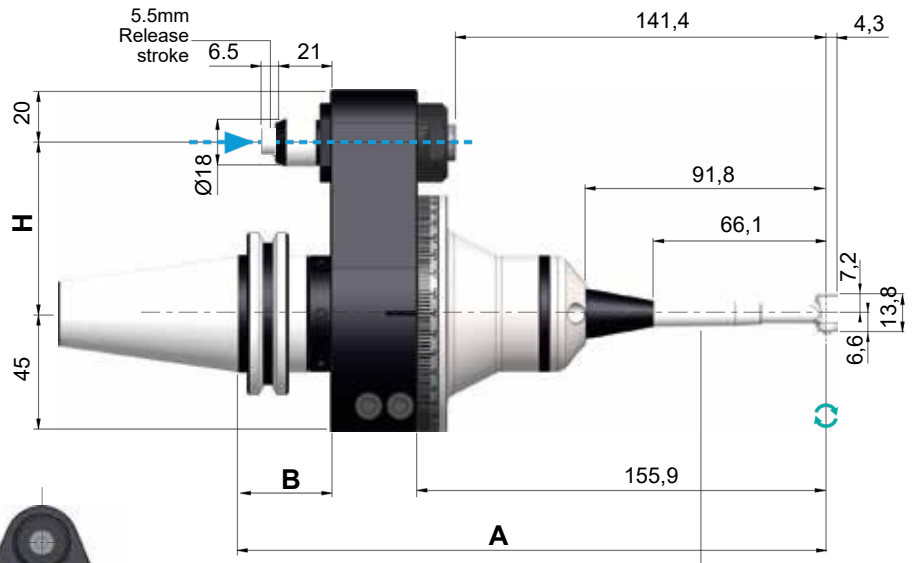

90° ANGLE SPINDLE  
MFC - 300 S

▶ IDEAL FOR COUNTERSINKING AND SNAGGING ◀

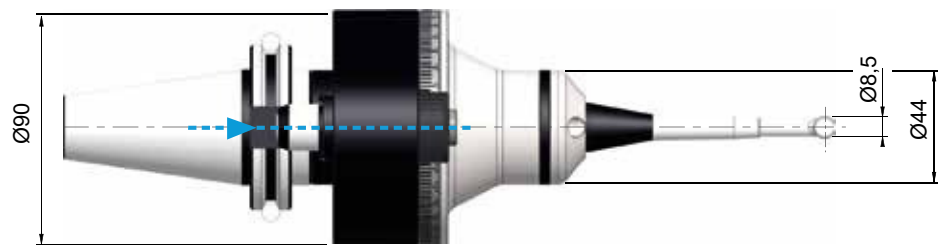

↻ Direction of rotation Same as the machine spindle

Technical data

Reduction Ratio 1:-1  
Kg 3,6  
Rpm 15.000  
Ø 1,6 Max  
Nm 1  
K252 Ø1,6

Coni - Shanks	SK DIN 69871			CAT ANSI B5.50		BT MAS 403			HSK DIN 69893			C. ISO 26623		
Size	30	40	50	40	50	30	40	50	63	80	100	C5	C6	C8
Dual contact (Optional)														
<b>H</b> Standard	65 / 80	65 / 80	80	65 / 80	80	65 / 80	65 / 80	80	65 / 80	65 / 80	80	65 / 80	65 / 80	80
Optional 110														
<b>A</b>	223,8	223,8	223,8	223,8	223,8	223,8	223,8	229,8	230,8	230,8	233,8	226,8	226,8	228,8
<b>B</b>	35	35	35	35	35	35	35	41	42	42	45	38	38	40

PACK WEIGHT: Bag 7Kg



**STANDARD EQUIPMENT**  
Specialbag / Stop block / ERnut / Wrenches / Greasetube  
Instruction book / K252 Ø1,6mm collet

OPTIONS

- 90° ANGLE SPINDLE - RA-100
- 90° ANGLE SPINDLE - IC-300
- 90° ANGLE SPINDLE - RA-200
- EXTENSION - CN-01 H=50,1 mm