

GTU-10 TYPE 0

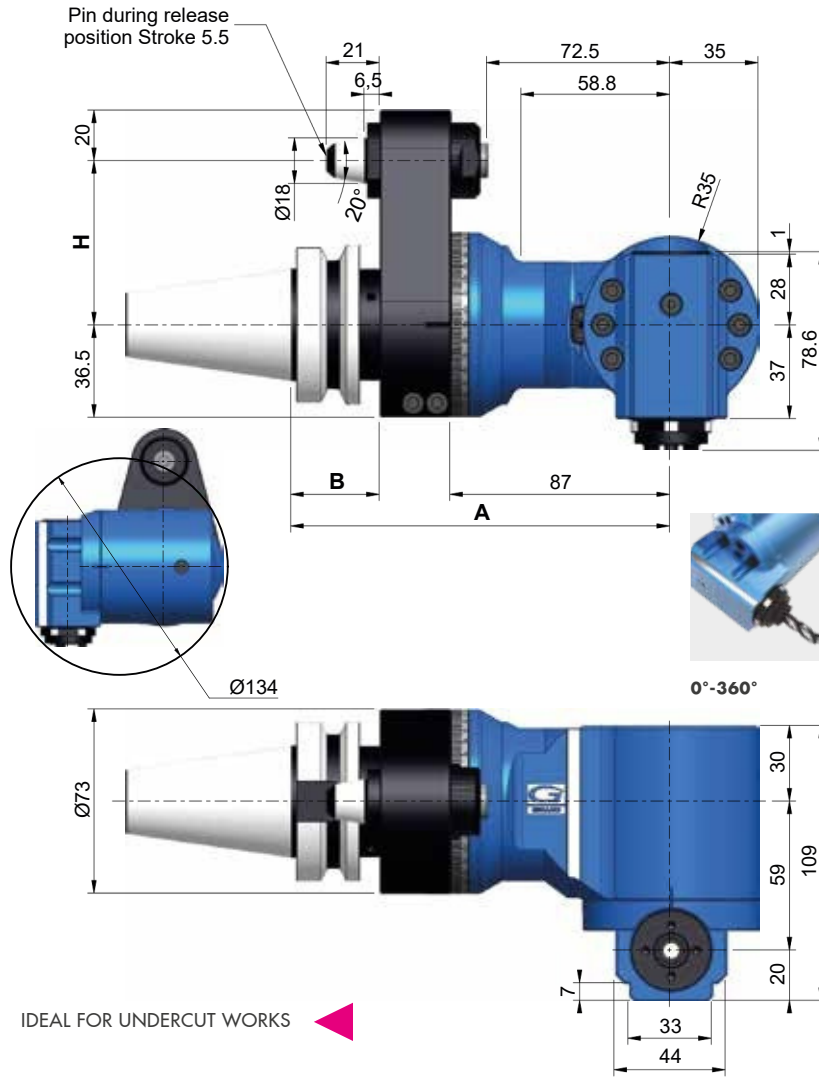

▶ IDEAL FOR UNDERCUT WORKS ◀



Technical data

	Ratio 1:1		ISO / BT40 Kg 3,8
	Rpm 6.000		Ø 10
	N 250		M 8
	Nm 10		ER16 Ø1/10

Senso di rotazione Uguale al mandrino - Direction of rotation Same as the machine spindle

Coni - Shanks	SK DIN 69871			CAT ANSI B5.50		BT MAS 403			HSK DIN 69893			C. ISO 26623			
Size	30	40	50	40	50	30	40	50	63	80	100	C5	C6	C8	
Dual contact (Optional)															
H	Standard	65 / 80	65 / 80	80	65 / 80	80	65 / 80	65 / 80	80	65 / 80	65 / 80	80	65 / 80	65 / 80	80
	Optional 110														
A	150	150	150	150	150	145	150	156	157	157	160	173	173	175	
B	35	35	35	35	35	30	35	41	42	42	45	38	38	40	

PACK WEIGHT:
Bag 7Kg



STANDARD EQUIPMENT

Special bag / Stop block / ER nut / Wrenches / Grease tube / Instruction book

OPTIONS

HIGH SPEED - 8000 Rpm

QUICK POSITIONING - Customized Angles

OUTPUT -Weldon Max Ø12

OUTPUT - ER20