

# Hard Jaws 4 Type

S / Series

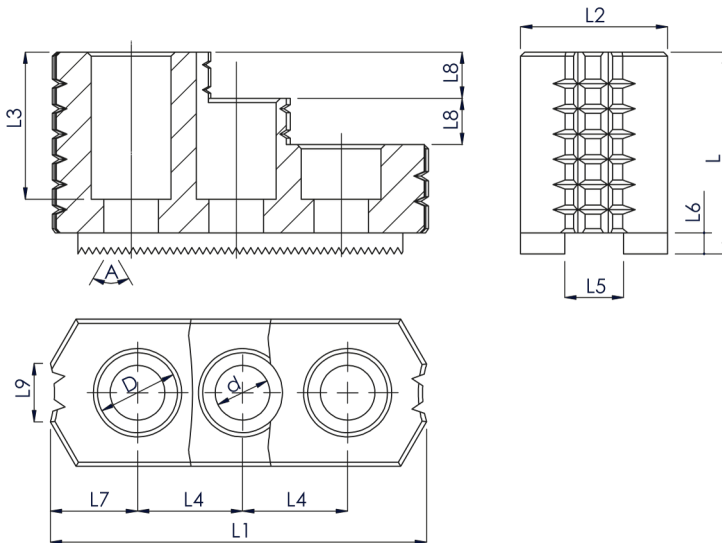

Order Code	Dimensions														Weight (kg.)
	Chuck Dia	Serration	L	L1	L2	L3	L4	L5	L6	L7	L8	L9	D	d	
S064	6"	1.5" X 60°	37	72	31	25	20	12	5	17	10	12	17	11	1,5
S084	8"	1.5" X 60°	48	90	35	35	25	14	5	19	11	13	19	13	3
S0104	10"	1.5" X 60°	58	102	40	42	30	16	5	25	14	16	19	13	4,5
S0124	12"	1.5" X 60°	65	110	50	48	30	21	5	30	15	19	25	17	13,5
S0154	15"	1.5" X 60°	87	150	62	63	43	22	8	34	20	21	32	21	15,5